

A Novel Fluid Level Sensor: Dual Purpose, Autoranging, Self-Calibrating

by L. Douglas Clark, Ph.D.

Abstract

A low-cost fluid level sensor probe determines depth of insertion in isotropic fluids independent of their electrical conductivity or dielectric constant. The probe system determines the electrical properties of the fluid, selects the appropriate measurement method, conductivity or capacitance, then calculates the depth of insertion of the probe into the fluid being studied. Readouts include depth of insertion, dielectric constant, and electrical conductivity. The probe system is autoranging and self-calibrating.

Introduction

Many internal-combustion vehicles of today run on a mixture of gasoline, ethanol, and other fuel additives. It is desirable to use a rugged, inexpensive gauge to indicate the level of fuel in the vehicle's fuel tank. Capacitive or conductive measurement probes can be used in this application, but they suffer from serious deficiencies. Prior-art capacitive sensor depth probes are unsuitable for use with these mixtures because of the complex variation of dielectric constant as a function of concentration of the various species. The same is true for prior-art conductivity sensor depth probes. The effect of temperature on these measurements is also a concern.

A depth measurement probe which does not suffer from these deficiencies is described herein. The probe is mechanically simple and uses autoranging electronic circuitry to measure both fluid properties and depth of insertion of the probe into a fluid.

The electrical conductivity, σ , of gasoline is very low, typically less than one picoSiemens (pS)/cm. Its relative dielectric constant, ϵ_r , is approximately 2.0. The electrical conductivity of ethanol is approximately 10^{-9} S/cm. Its relative dielectric constant is approximately 24. As the gasoline-ethanol mixture is varied from zero to 100% ethanol, the electrical conductivity varies by three orders of magnitude, and the dielectric constant varies by one order of magnitude. In addition, these variations are not linear with concentration. Still further, they do not reflect the presence of fuel additives

which can cause additional variations. These are the variations that render prior-art probes unsuitable for use as depth sensors for gasoline-ethanol mixtures.

Gasoline-ethanol mixtures were chosen for analysis in this work to demonstrate the suitability of the present depth sensor probe for use with these fluids.

The Dual-Purpose Probe—Fig. 1

The depth sensing probe used in this work is described in detail in U.S. patent 6,265,883 (2001). The size of the probe was chosen to demonstrate its potential use in ordinary vehicle fuel tanks.

The probe is made of stainless steel tubing. It contains one inner and two outer coaxial, cylindrical electrodes. The electrodes are held in place with respect to one-another by insulating dowel pins made of acetal plastic (polyoxy-methylene polymer). The probe assembly is suspended by an insulator (not shown).

The overall probe assembly is approximately 30.2 cm long. A long, upper electrode is 29 cm long. A short, lower electrode is 1.2 cm long. The inside diameter of the upper and lower electrodes is 11 mm. The upper and lower electrodes are separated by a small gap of 0.5 mm. The outside diameter of the inner electrode is 8 mm. The inner electrode extends in a single piece from the top of the upper electrode to the bottom of the lower electrode.

The diameter of the acetal dowel pins is 1.59 mm. Six of these dowel pins are used to attach each outer electrode to the inner electrode.

The probe is oriented so that the lower electrode is immersed in the liquid being measured. The lower electrode provides the driving voltage to measure the conductivity or dielectric constant of the fluid being studied. The upper electrode provides the driving voltage to measure the depth of insertion in the fluid.

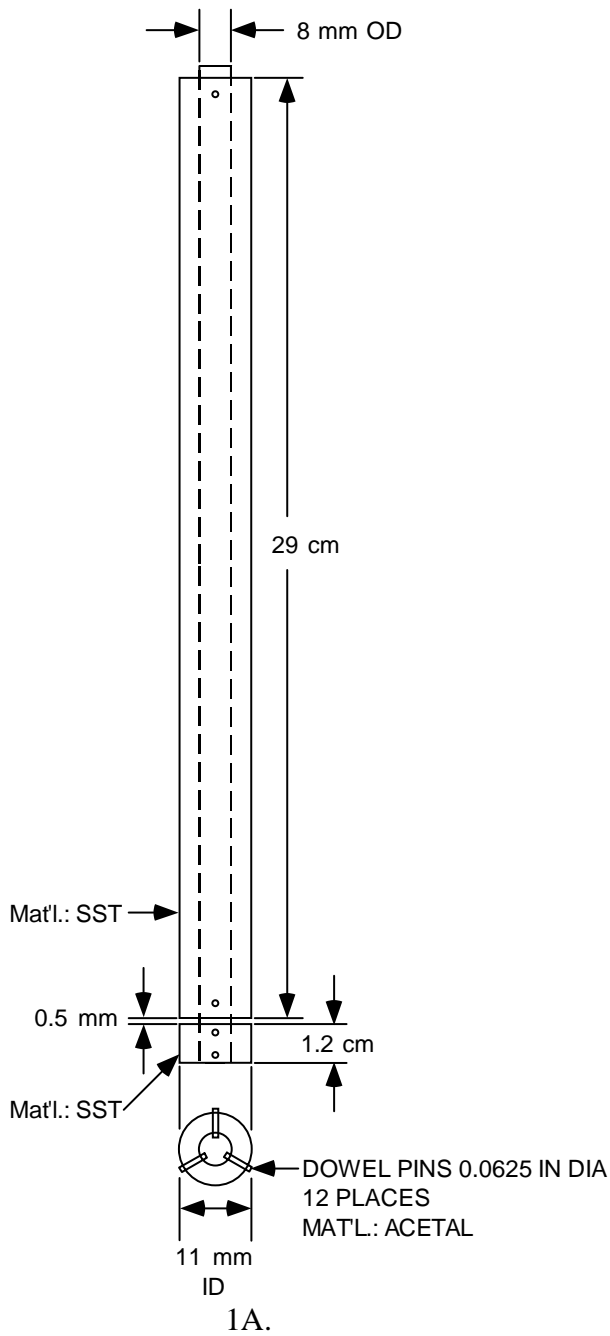

Figs. 1A and 1B. The Dual Purpose Probe

The Probe Electronics—Fig. 2

The probe electronics are shown in Fig. 2. To reduce cost and simplify the circuitry as much as possible, square waves are used for all measurements.

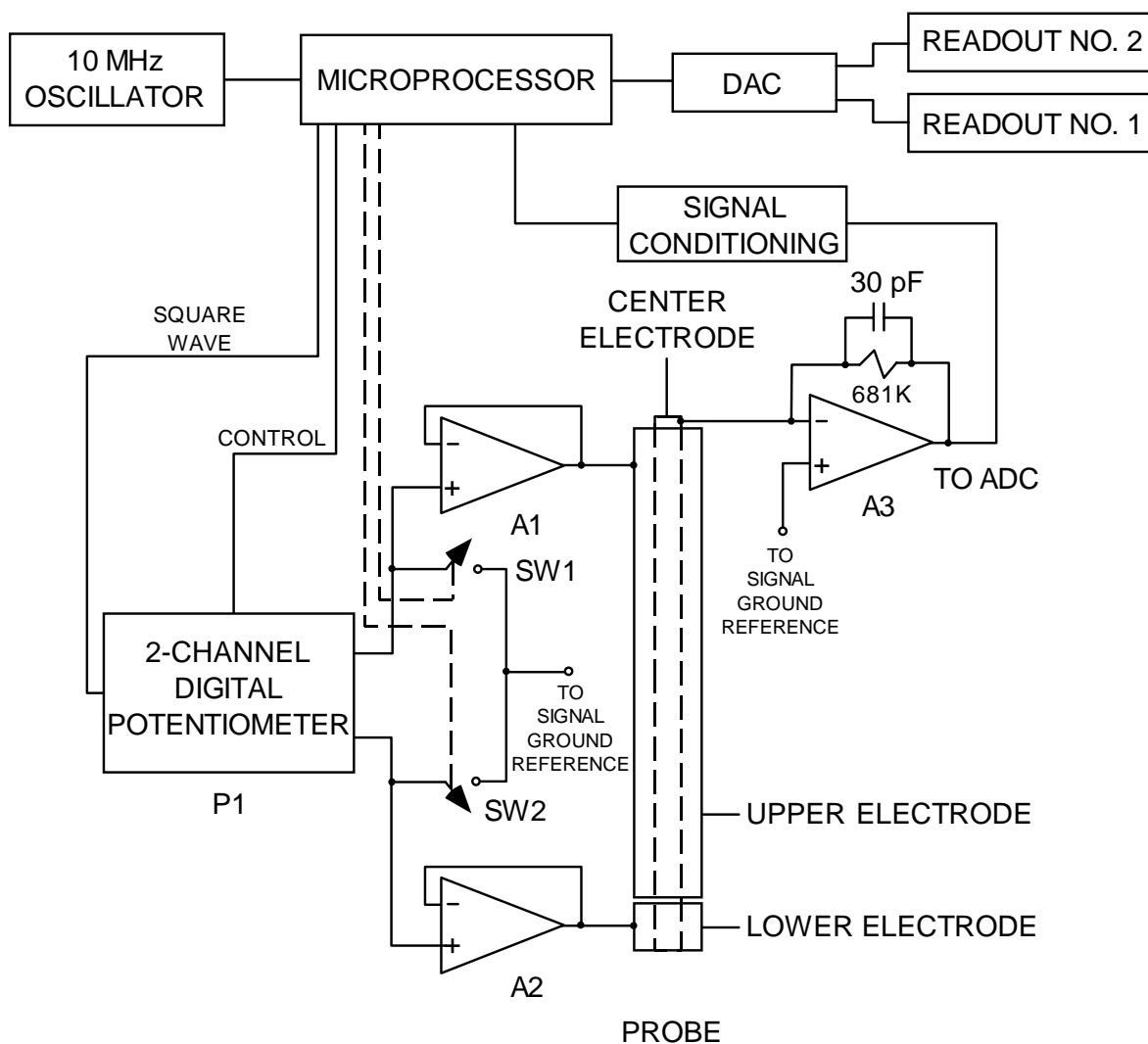

Fig. 2. The Probe Electronics

The heart of the electronics is an inexpensive, off-the-shelf, 8-bit microprocessor. The microprocessor is clocked by a 10 MHz oscillator. Operation of the microprocessor is controlled by firmware stored in its internal program memory. Program-generated square waves from the microprocessor are applied to a two-channel digital potentiometer. Under program control, the microprocessor adjusts the amplitude of the signal applied to the upper and lower electrodes.

The upper and lower electrodes are driven by low-impedance sources, in this case operational amplifiers. Analog switches are used in front of the amplifiers to eliminate spurious signals.

The inner electrode is connected to a third operational amplifier with predetermined gain and frequency response. The output of this amplifier is connected to a 10-bit Analog-to-Digital Converter (ADC) within the microprocessor. The amplifier output is filtered by signal conditioning circuitry.

Data from the ADC are analyzed by the microprocessor program. Values representative of the signals produced by excitation of the upper and lower electrodes are sent to a Digital-to-Analog Converter (DAC). These values are displayed on readouts 1 and 2.

Waveforms—Fig. 3-4

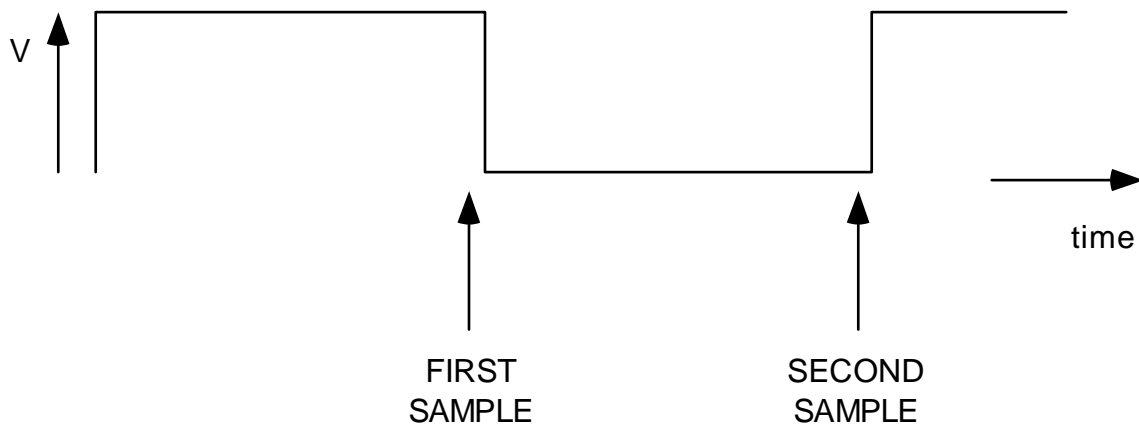

Fig. 3. Electrode drive voltage and ADC sampling times for conductivity measurement.

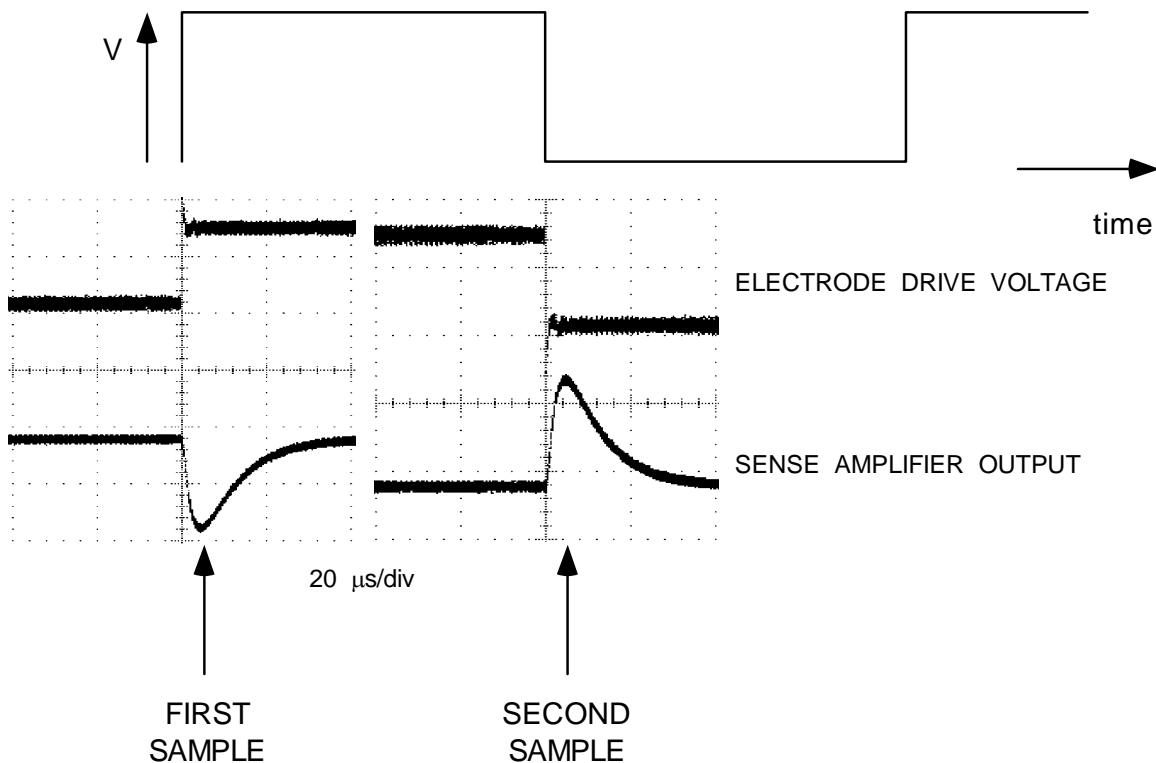

Fig. 4. Electrode drive voltage and ADC sampling times for capacitance measurement.

The upper and lower electrodes are driven by square waves. For conductivity measurement, a 70 Hz square wave is used. For capacitance measurements, a 136 Hz square wave is used.

During conductivity measurements, the output of the sense amplifier (A3 in Fig. 2) is sampled at the end of every half-cycle. At this point, all transient effects have died out and only the DC component of conductivity remains. The feedback resistor value 681K was chosen to maximize the signal amplitude range resulting from the choice of fluids and the size of the probe.

During capacitance measurements, the output of the sense amplifier is sampled shortly after the first transition of every half-cycle. The value of the feedback capacitor, 30 pF, on amplifier A3 was chosen to maximize the signal amplitude range for capacitance measurements.

The amplitude of the driving voltage is determined by the microprocessor program, as explained below.

The Microprocessor Program—Figs. 5-8

Differenced signals are averaged throughout this program. Taking differences between first and second samples (Figs. 3 and 4) removes the undesired DC component of the signal.

Averaging signals containing random noise improves the resulting signal-to-noise ratio by the square root of the number of samples averaged. When drive levels are being set, only four sampled differences are averaged. This provides an adequate estimate of the drive level required for each measurement. During actual measurements, sixty-four sampled differences are averaged for each program step. This provides a steady 10-bit result for data analysis leading to the final depth measurement.

At startup, the program checks for a predetermined level of conductivity in the fluid. If this level is not found, the program defaults to a capacitance measurement. When either measurement is successful, the program remains in that mode and outputs signal values to readouts 1 and 2 (Fig. 2). After indicating the results of measurements for a period of time, the program may optionally be returned to its startup step. This is done to ensure that the auto-ranging function uses optimal signal values.

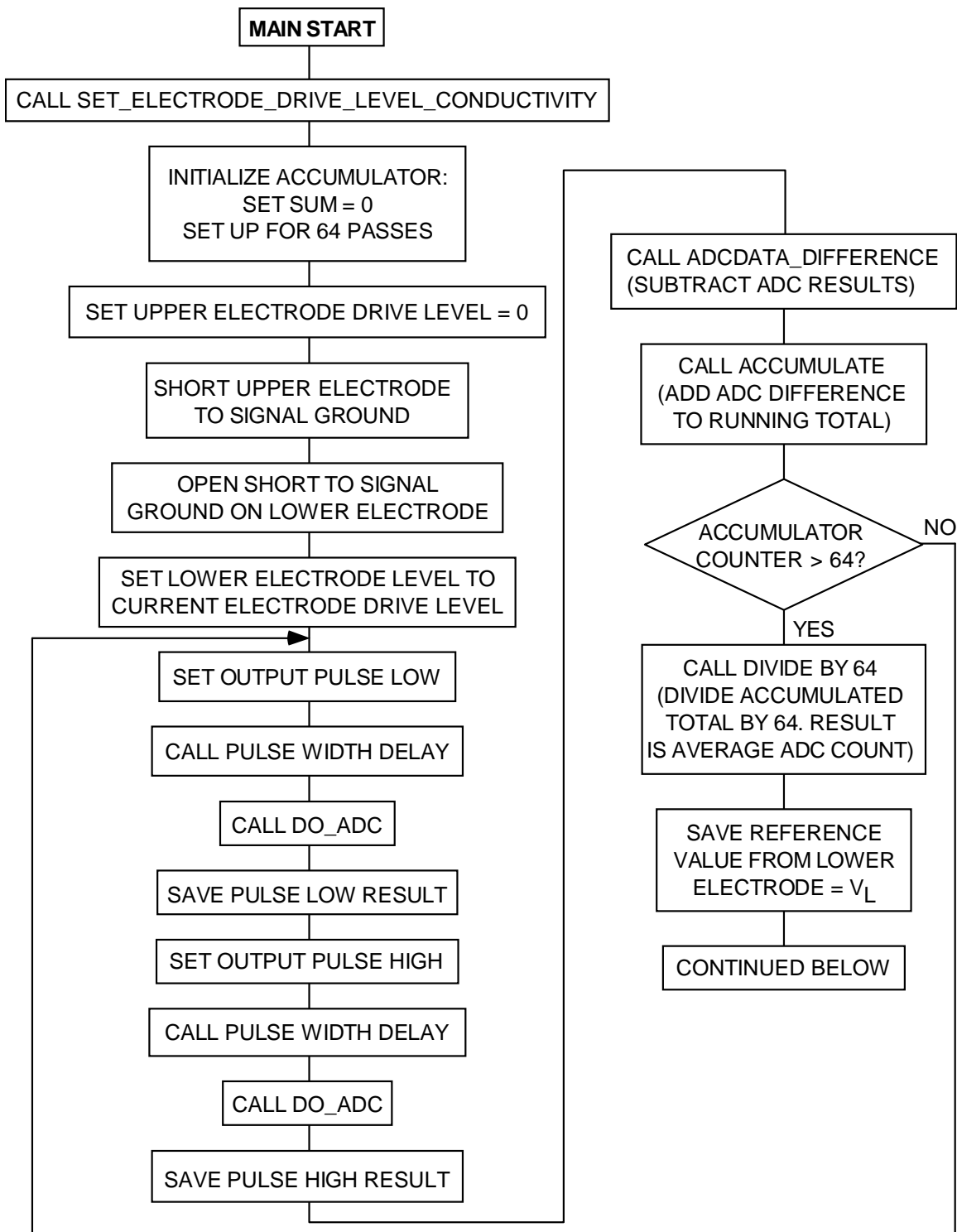

Fig. 5. The Main Program (continued on next page).

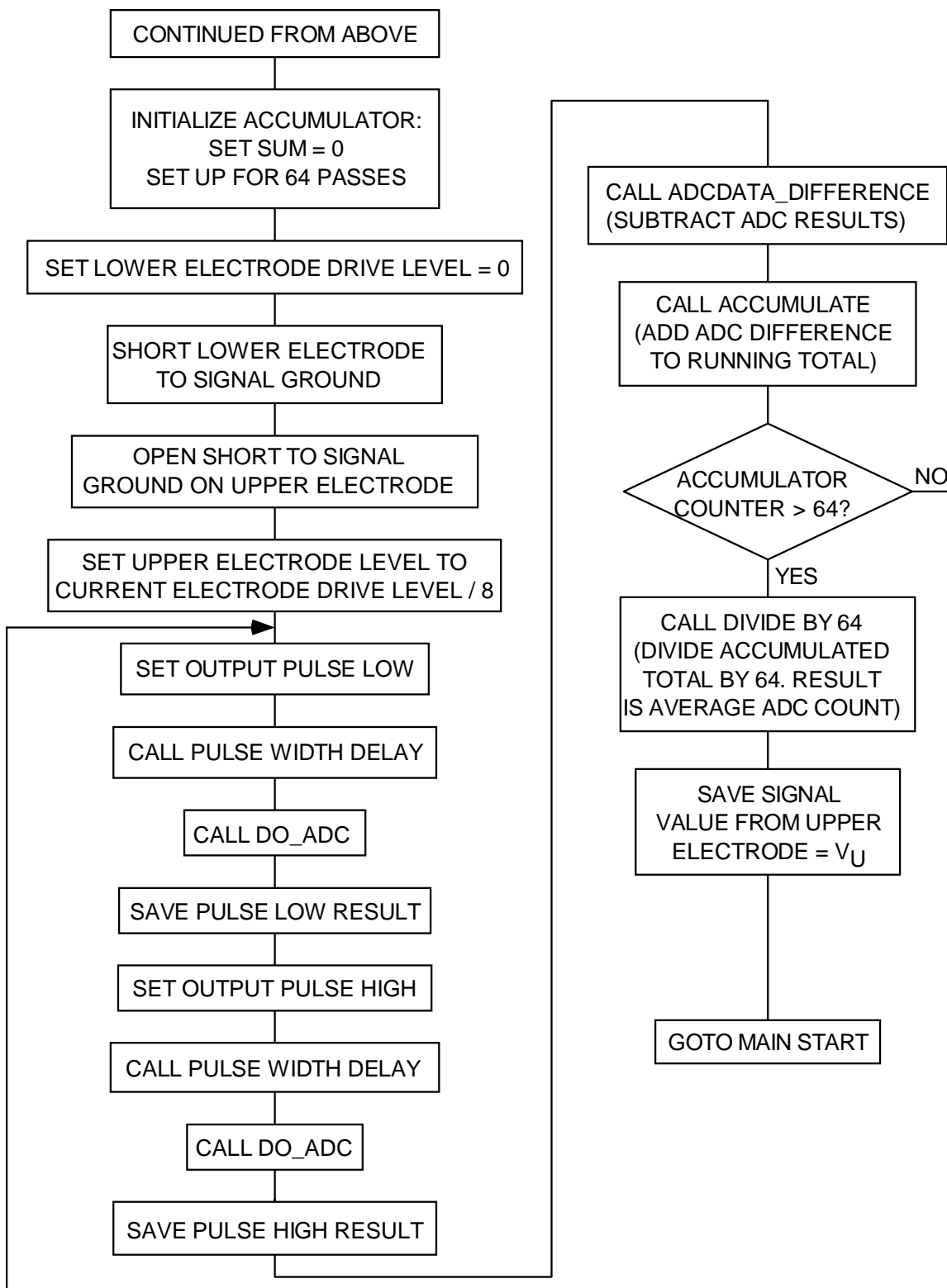

Fig. 5. The Main program (continued from previous page).

The main program begins by using the lower drive electrode to check for a predetermined minimum conductivity in the fluid under study. The upper drive electrode is not used in this measurement. The main program first calls the subroutine SET_ELECTRODE_DRIVE_LEVEL_CONDUCTIVITY. See. Fig. 6.

SET_ELECTRODE_DRIVE_LEVEL_CONDUCTIVITY

The microprocessor (Fig. 2) applies a 70 Hz square wave to the inputs of the dual potentiometer. It then sends an instruction to potentiometer P1 to output a zero value of square wave to the lower electrode via amplifier A2. Switch SW2 is opened. The drive level of the upper electrode is also set to zero by potentiometer P1, and switch SW1 is closed.

An accumulator memory location is zeroed and set to add the difference between the first and second signal samples (Figs. 3 and 4) at the output of amplifier A3.

The program then outputs a high-to-low transition, resulting in a low analog value at the input of potentiometer P1. The microprocessor waits a predetermined amount of time equal to just less than one-half period of the signal driving the lower electrode. At the end of the first half-cycle, the ADC samples the waveform present at the output of amplifier A3. The ADC measurement result is saved in memory. Next the program outputs a low-to-high transition to potentiometer P1. The same steps are repeated and the result of the high analog value half-period of the drive signal is saved. Next, the two saved signals are subtracted and their difference is added to the accumulator. A counter associated with the accumulator is iterated and checked to see if four repetitions have occurred. If not, program execution returns to the point where the output pulse executed a high-to-low transition and the above process repeats.

If four differences have been added in the accumulator, the resultant number is divided by 4. This is the average of four passes through the data acquisition phase of this subroutine.

If the average is greater than a predetermined value, then this subroutine is finished and execution returns to the main program with a known electrode drive level to be used in subsequent measurements.

If the average is less than the predetermined value, the lower electrode drive level is incremented and execution of the subroutine branches to reset the accumulator and average a new set of signal differences.

If the fluid being studied has a very low conductivity value, the highest electrode drive level will not be sufficient to reach the predetermined value for conductivity measurements. When this happens, the subroutine branches to another subroutine called CAPACITIVE_SENSE, shown in the flow diagrams of Figs. 7 and 8.

Measurements Using the Upper Electrode

In the following, assume the predetermined value of conductivity was found. Execution returns to the main part of the program. In the main program for conductivity, a procedure similar to the above steps is applied to signals averaged when the lower electrode is driven. Next, the upper electrode is driven while the lower electrode is held at signal ground level. The resultant value obtained from the upper electrode reflects the depth of insertion of the upper electrode in the fluid being studied. The calculation for determination of depth is very simple. In addition, the conductivity can be determined its value indicated on a readout attached to the microprocessor. These calculations are discussed below.

If instead the program branches to the CAPACITIVE_SENSE subroutine, the frequency of the square waves applied to the probe electrodes is increased. This is done to speed the measurements. It is possible to speed the capacitive measurements since there is only a short asymptote returning to zero after each pulse is applied to the probe drive electrodes. The same procedure is applied for capacitive measurements as for conductivity measurements. In this case, the dielectric constant of the fluid being studied can be determined and indicated on a readout, if desired. These calculations are also discussed below.

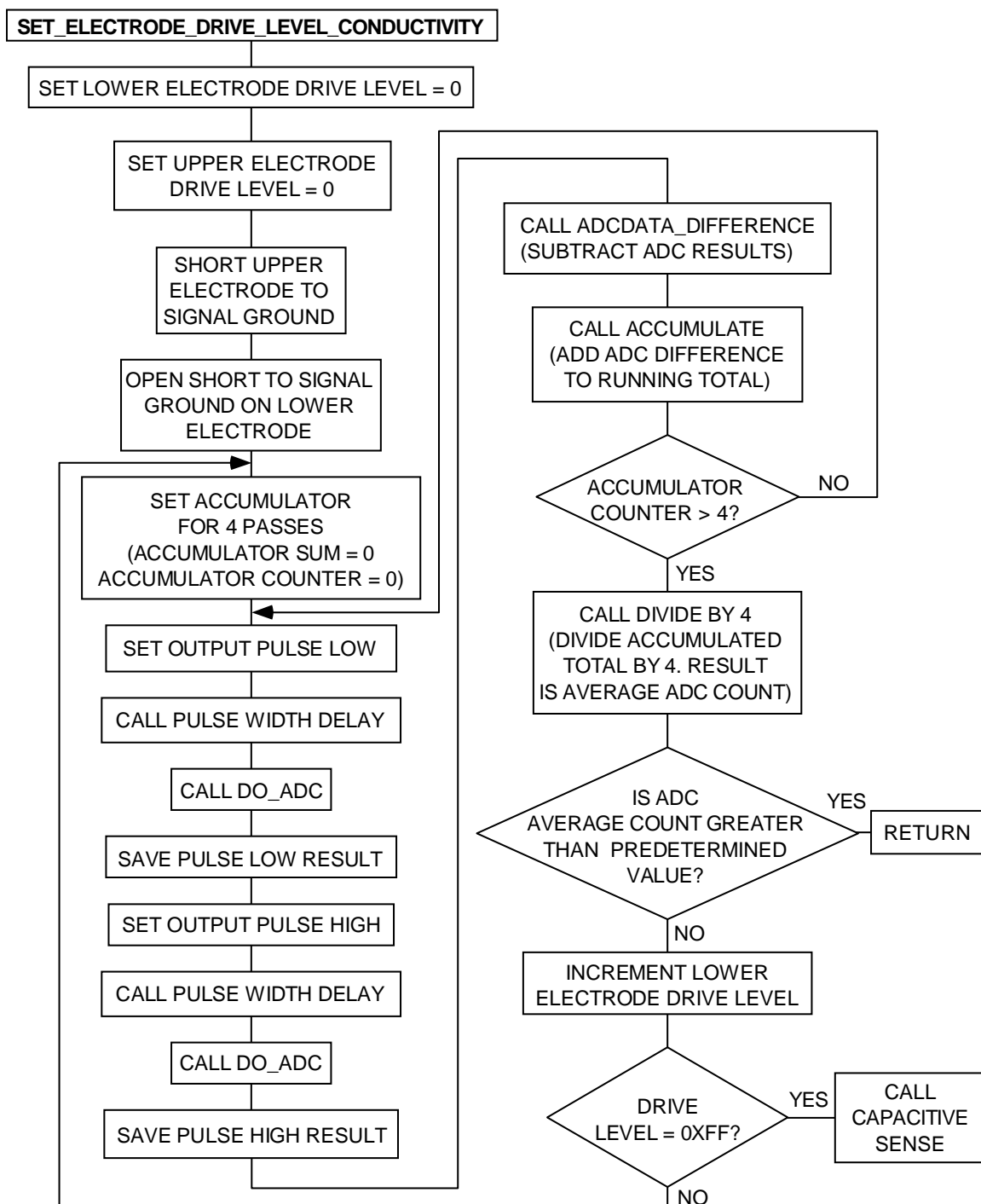

Fig. 6. SET_ELECTRODE_DRIVE_LEVEL_CONDUCTIVITY Subroutine

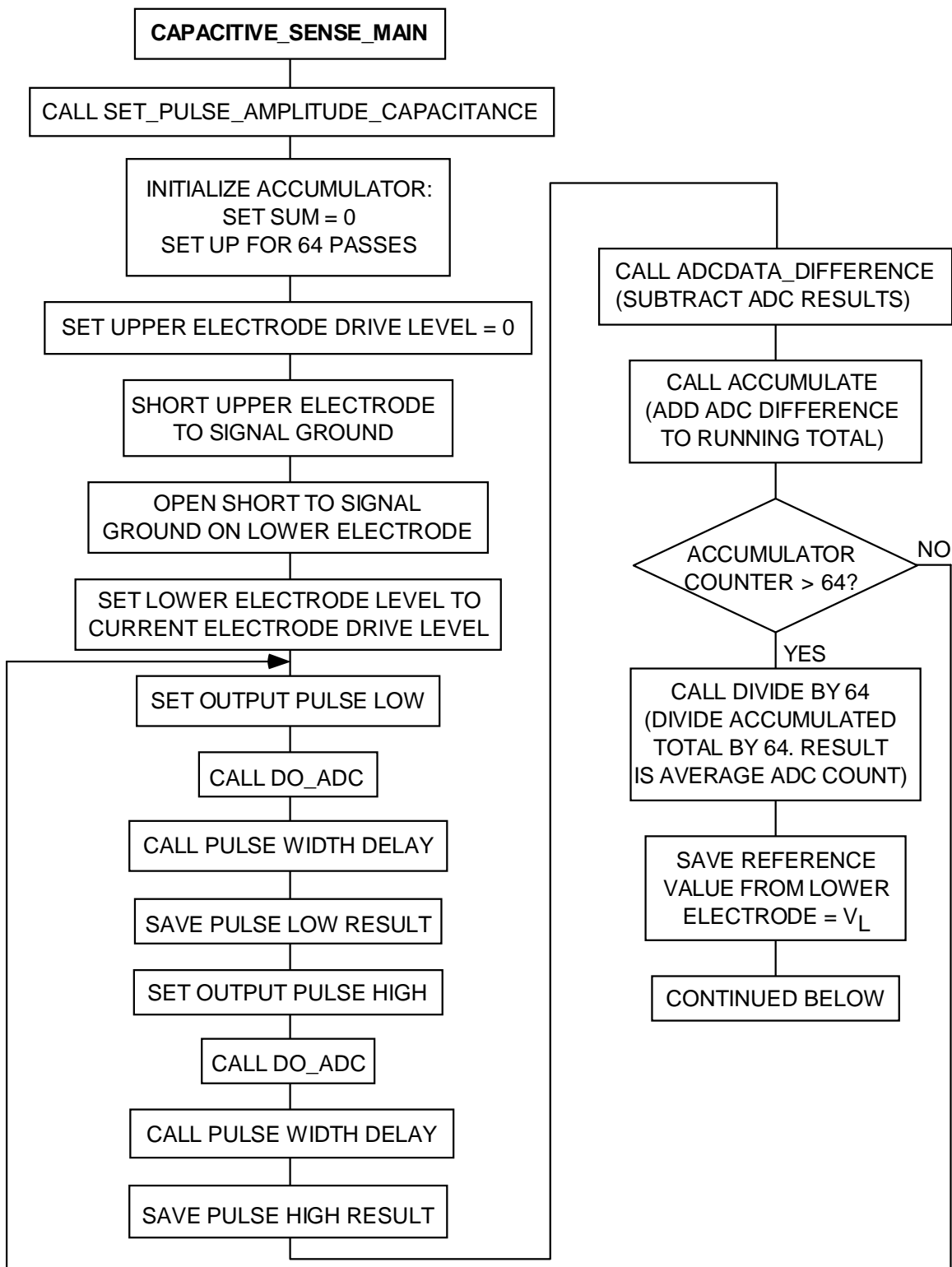

Fig. 7. CAPACITIVE_SENSE Subroutine (continued below)

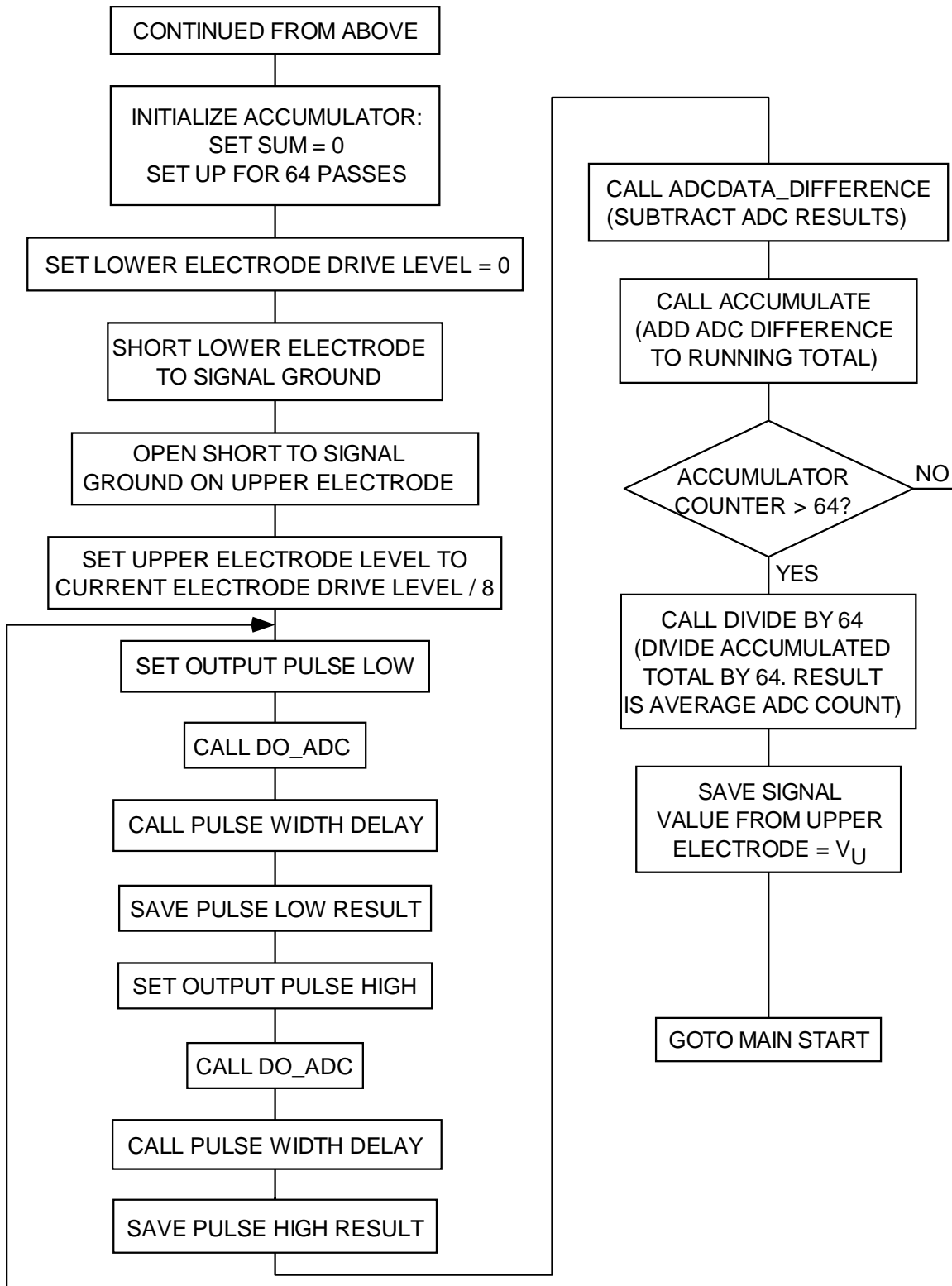

Fig. 8 CAPACITIVE_SENSE Subroutine (continued from above).

CALCULATIONS

Conductivity measurements

Reference calculation—conditions:

Lower electrode active

Upper electrode inactive and shorted to signal ground

CONDUCTIVITY

The electrical conductivity of the fluid is given by

$$\sigma = j / E, \text{ where} \quad (1)$$

σ = conductivity,

j = current density, and

E = electric field intensity between the probe's inner and outer electrodes.

The current flowing through the probe is determined by the electrode drive voltage and the feedback resistor on amplifier A3.

$$i = V_{\text{out A3}} / 681\text{k ohms} \quad (2)$$

The current density at the surface of the inner probe electrode is

$$j = i / A, \quad (3)$$

where A is the area of the inner electrode receiving current due to the lower electrode drive voltage. For the present probe, $A = 5.9 \text{ cm}^2$. (The area occupied by the six insulating dowel pins has been subtracted from the electrode area.)

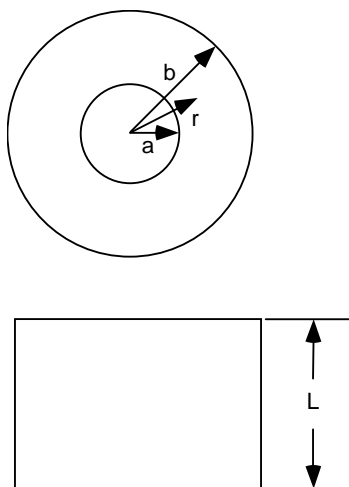

Fig. 9.

The intensity of the electric field between the coaxial conductors is given by:

$$E = \frac{V}{r \ln(b/a)} \quad (4)$$

where V is the electrode drive voltage, r is the distance from the center of the electrode pair, a is the diameter of the inner electrode, and b is the inside diameter of the outer electrode. At the surface of the inner electrode,

$$E = V_{\text{drive}} / 3.3 \text{ volts/cm.} \quad (5)$$

Thus the conductivity is easily calculated from:

$$\sigma = V_{\text{out A3}} \times 6.4 \times 10^{-8} / V_{\text{drive}} \text{ S/cm.} \quad (6)$$

DEPTH

The depth of insertion of the probe in the fluid of interest is more easily calculated. A voltage proportional to the conductivity of the fluid is supplied on readout 1 (Fig. 2). A voltage proportional to the conductivity of the fluid times the depth of insertion of the upper electrode portion of the probe is supplied on readout 2. Dividing the larger reading by the smaller one and multiplying by the length of the lower electrode yields the depth of insertion of the upper electrode. The depth of insertion of the upper electrode is measured from the gap between the electrodes.

In order to maximize the dynamic range of the electronics, the drive voltage applied to the upper electrode is approximately one-eighth that applied to the lower electrode. Thus the voltage on readout 2 is multiplied by 8.16 (the actual number) in the depth calculation.

In this particular probe, the length of the lower drive electrode is 1.2 cm. The above quotient is multiplied by 1.2 to compensate for this.

Thus for this circuit and probe, the computed depth of insertion is given by:

$$y \text{ (cm)} = \text{Readout}_2 \times 8.16 \times 1.2 / \text{Readout}_1. \quad (7)$$

CAPACITANCE AND DIELECTRIC CONSTANT

Capacitance measurements

Reference calculation—conditions:

Lower electrode active

Upper electrode inactive and shorted to signal ground

An initial capacitance measurement is made with the probe electrodes in air. The microprocessor program is started. After finding no measurable conductivity between the electrodes, the program defaults to capacitance mode. The autoranging function sets the drive level of the lower electrode. A number directly proportional to the capacitance between the lower drive electrode and the center electrode of the probe is displayed on readout 1. This number is saved in the EEPROM memory of the microprocessor for use in calculations, as described below. At this point, the program contains all the calibration data required for this particular probe. This calibration need be done only once, however it can be repeated at any time if desired. (If the probe is to be used in an environment containing a gas other than air, the one-time calibration must be done in the presence of that gas.)

The capacitance between the lower drive electrode and the inner electrode is given by:

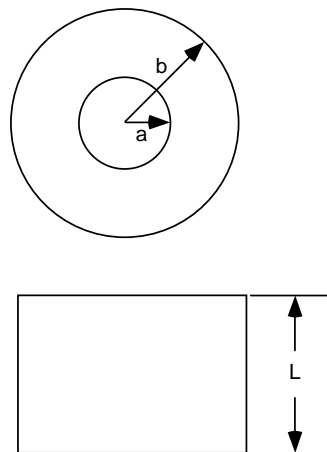

Fig. 10

$$C_L = 2\pi \epsilon_0 \epsilon_r L / \ln(b/a), \text{ where} \quad (8)$$

$\epsilon_0 = 8.85 \times 10^{-14}$ F/cm, the permittivity of free space,

ϵ_r is the relative dielectric constant of the medium between the electrodes,

a is the radius of the inner electrode, and

b is the inside radius of the outer electrode.

The measured capacitance of the lower-inner electrode combination consists of four parts. The medium between the electrodes is either air or the fluid under study. The capacitance is a function of the dielectric constant of the medium. The acetal dowel pins mentioned above increase the capacitance slightly by a fixed amount when the medium is air. Fringing electric fields also increase the measured capacitance slightly. Conductor-to-conductor capacitance is slightly reduced because of the presence of the dowel pins. In air, the capacitance of the lower-inner electrode pair is about 1.5 pF.

The upper electrode-inner electrode pair is partially submerged in the fluid under study.

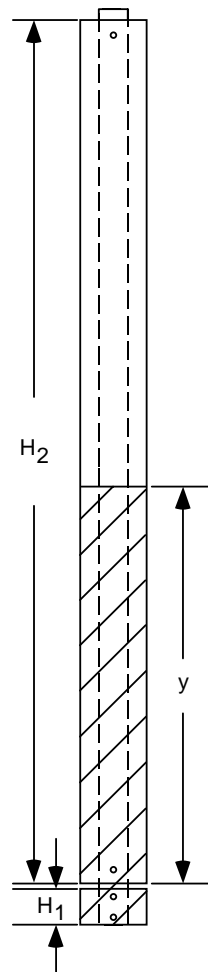

Fig. 11

The capacitance of upper electrode-inner electrode pair is given by:

$$C_U = \frac{2\pi}{\ln(b/a)} \epsilon_0 \left(\epsilon_T y + (H_2 - y) \right) \quad (9)$$

The depth of insertion of the upper electrode-inner electrode pair can be obtained from the quotient of C_U and C_L as given in the above equations. Dividing and solving for y yields:

$$y = \frac{\epsilon_T H_1 \frac{C_U}{C_L} - H_2}{\epsilon_T - 1} \quad (10)$$

The values of capacitance of the upper electrode-inner electrode pair and the lower electrode-inner electrode pair are directly proportional to the readings on readouts 1 and 2 (Fig. 2). Therefore,

$$\text{Readout}_2 \times 8 / \text{Readout}_1 = C_U / C_L. \quad (11)$$

The reason for the factor of 8 was described above in connection with the conductivity measurement. The same factor is used in the capacitance measurement.

DEPTH MEASUREMENTS

CONDUCTIVITY

The conductivity values below were obtained using Readout_1 to measure the signal level derived from amplifier A3, and an oscilloscope to measure the lower electrode drive voltage. The latter measurement and the conductivity calculation can be done within the microprocessor program, if desired.

For ethanol, $V_{A3} = 77$ mV and $V_{DRIVE} = 308$ mV. Using the above formula for conductivity yields $\sigma = 1.6 \times 10^{-8}$ S/cm. The measurement temperature was 21 deg. C. The published value for ethanol is 1.35×10^{-8} S/cm. The discrepancy is likely due to the purity of the ethanol studied here.

The depth of insertion of the probe into ethanol was determined solely from the quotient of readouts 1 and 2, and the correction factors, as described above. A plot showing depth measurements for a variety of fluids with conductivity greater than about 10^{-9} S/cm is shown below. In each case, the lower electrode of the probe was inserted in the fluid with the circuitry OFF. Then the circuit was turned ON, the autoranging function set the appropriate drive level, and depth measurements commenced. With the present software, changes in depth were indicated within about two seconds. A heavy line from 0 to 20 cm is included for reference.

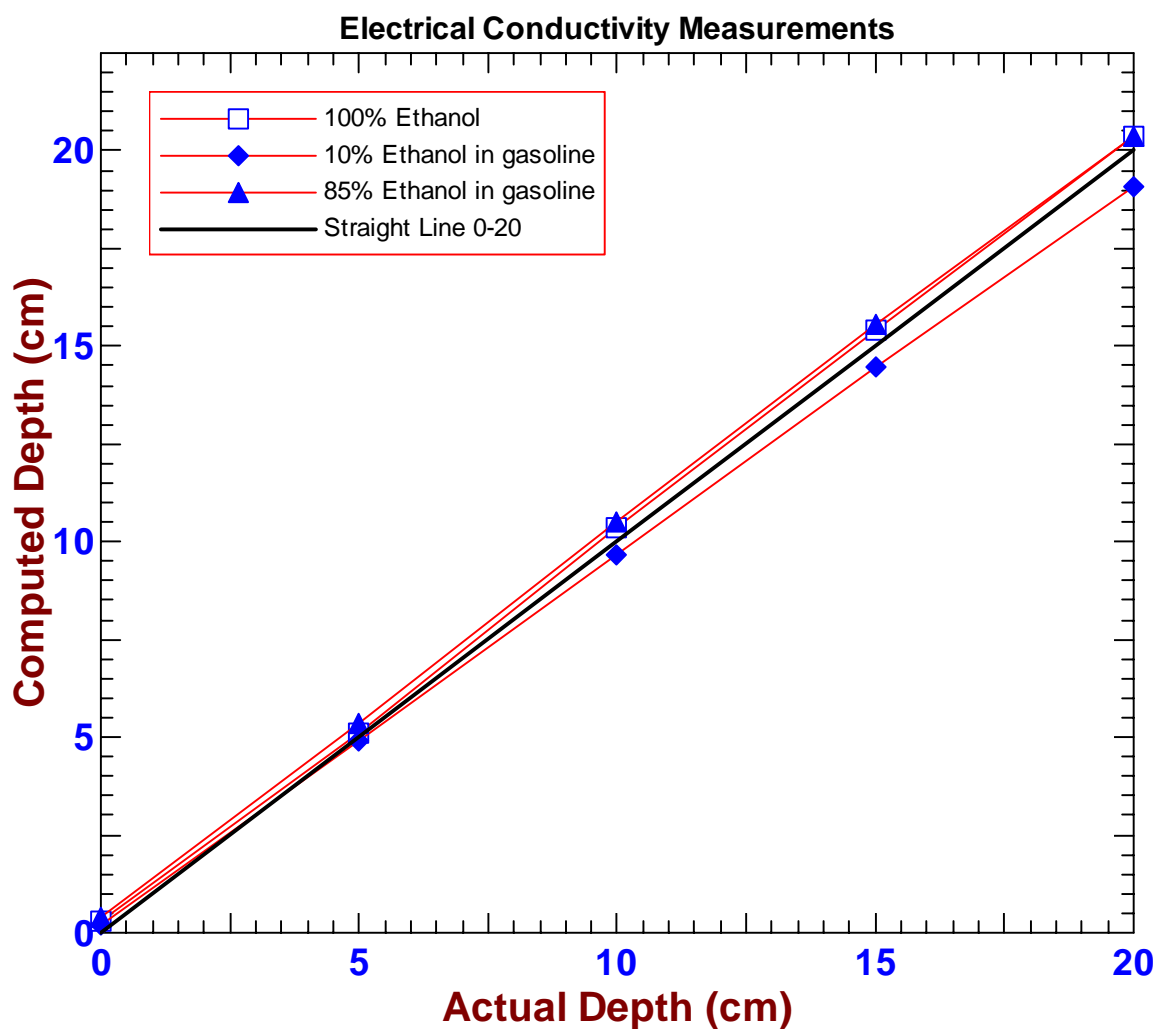

Fig. 12

CAPACITANCE

As discussed above, a first value of capacitance for the lower electrode-inner electrode pair in air was stored. The relative dielectric constant of the fluid being studied is then determined from the change in capacitance noted as the lower electrode is inserted into the fluid. This change is indicated by subsequent readings of Readout_1. A geometric factor of 1.16 accounts for the acetal dowel pins.

$$\epsilon_r = (\text{Readout}_1 \text{ (air ref)} / \text{Readout}_1 \text{ (fluid measurement)}) \times 1.16 \quad (12)$$

The factor of 1.164 corrects for the presence of the dowel pins in the lower electrode. It is the ratio of the total electrode area including the dowel pins and the actual metal area.

The depth of insertion of the probe for various fluids is shown in the graph below. As in the case of conductivity measurements, drive level and geometrical corrections are included in the depth calculations leading to the plots. A heavy line from 0 to 20 cm is included for reference.

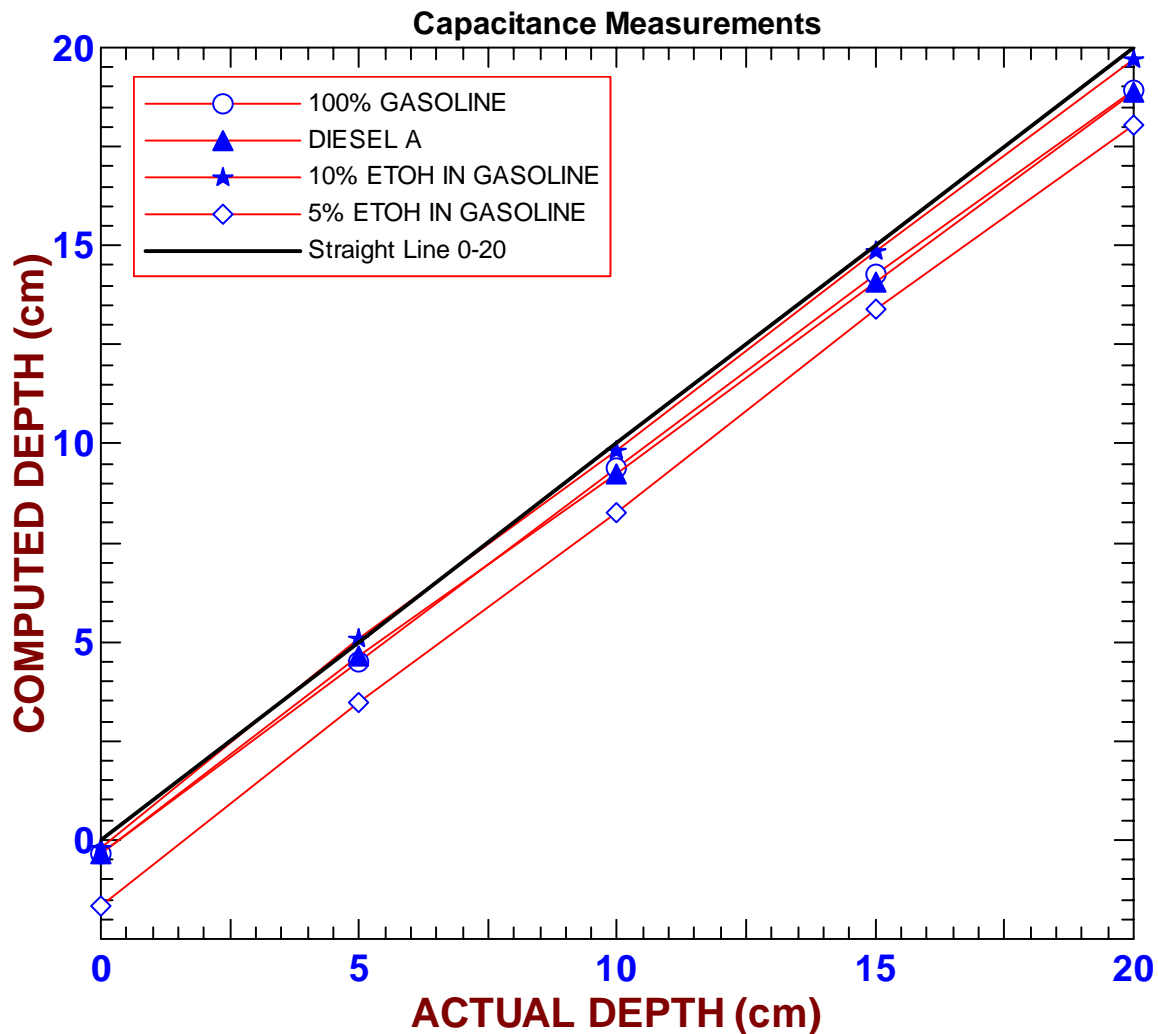

Fig. 13

CONCLUSION

An low-cost, three-electrode, dual purpose, autoranging, self-calibrating depth measurement probe system has been discussed and its use demonstrated. Depth calculations are made from first principles using the geometry of the probe and properties of the probe materials and the fluid under study. The construction of the probe is very simple and rugged. Measurements can be made in high and low temperature and pressure conditions. The probe can be used in many hazardous environments. Various hydrocarbon fuels have been the subject of this study, however the probe and electronics can be used with many other fluids. If desired, the probe system can be arranged to report values of electrical conductivity, relative dielectric constant, and temperature of the fluid.